



PZ-G62P

Square retro-reflective Cable Type, PNP



Specifications

Model	PZ-G62P	
Type	Retro-reflective ^{*1} Transparent object detection	
Shape	Rectangular	
Output	PNP	
Cable connection	Cable (2 m 78.74") ^{*2}	
Detecting distance	0.1 to 1 m 0.3' to 3.3' (When R-2L reflector is used)	
Spot diameter	—	
Light source	Infrared LED	
Sensitivity adjustment	1-turn trimmer (230°)	
Response time	500 μs	
Operation mode	LIGHT-ON/DARK-ON (switch-selectable)	
Indicators (LED)	Output: Orange LED, Stable operation: Green LED	
Control output	Open collector output, 30 V max., 100 mA max., Residual voltage: 1 V max.	
Protection circuit	Reversed polarity, overcurrent protection, surge absorber	
Interference suppression	Up to 2 units (with the automatic different frequency function)	
Tightening torque	Rectangular models (Mounting hole part): 0.5 N m max.	
Rating	Power voltage	10 to 30 VDC, including Ripple (P-P) 10 %
	Current consumption	34 mA or less
Environmental resistance	Enclosure rating	IEC: IP67/NEMA: 4A, 6, 12/DIN: IP69K
	Ambient light	Incandescent lamp: 5,000 lux max., Sunlight: 20,000 lux max.
	Ambient temperature	-20 to +55 °C -4 to 131 °F (No freezing)
	Relative humidity	35 to 85 % RH (No condensation)
	Vibration resistance	10 to 55 Hz, Double amplitude 1.5 mm 0.06", 2 hours in each of the X, Y, and Z directions
	Shock resistance	1,000 m/s ² , 6 times in each of the X, Y, and Z directions
Material	Housing, M18 nut (threaded models only)	Glass-fiber reinforced PBT
	Lens cover	Polyarylate (PAR)
	Trimmer	Glass-fiber reinforced polyamide (PA)
	Case connection	Screw: Nickel-plated iron and zinc, packing: nitrile butadiene rubber (NBR)
	Cable (cable models only)	Polyvinyl chloride (PVC)
	Connector (connector type with cable only)	—
Accessories	Instruction manual	
Weight	Rectangular cable models: Approx. 60 g (Thrubeam-models transmitter: Approx. 50 g)	
^{*1} Cable sold separately for connector models/pigtail quick disconnect models. Reflector sold separately for retro-reflective models. ^{*2} Cable sold separately for connector models		

Dimensions

* Download CAD file or product manual for larger image/text and more detail.

PZ-G61N/G61P/G62N/G62P

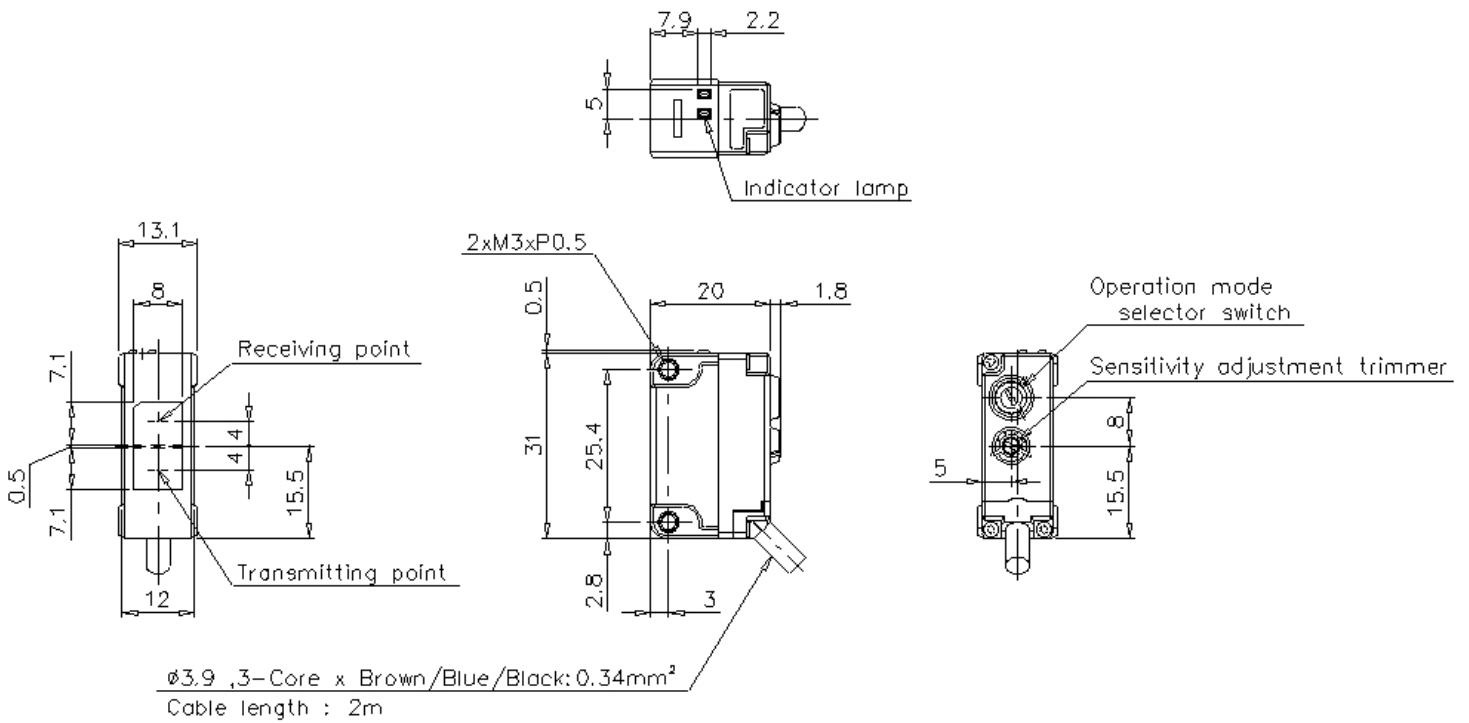

I/O Circuit Connection diagram

* Download CAD file or product manual for larger image/text and more detail.

PNP output
(thru-beam receiver, reflective, retro-reflective)

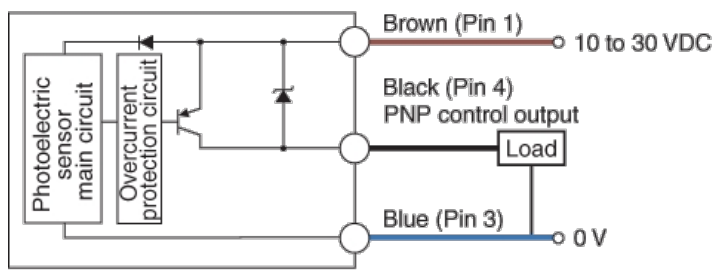

M8 connector
PZ-GxxCP

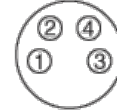

M12 connector
PZ-GxxEP

