



APEX DYNAMICS, INC.

**HIGH PRECISION
PLANETARY GEARBOX**

AE / AER Series



Stainless



Apex Dynamics, Inc. is the world's most productive manufacturer of servomotor drive planetary gearboxes for precision automation machinery. From our 800,000+ square foot ISO 9001:2008 manufacturing facility, based in Taichung, Taiwan, we manufacture to stock using the newest precision machine tools and quality test and inspection equipment. Complete focus on quality and precision allows us to produce our high quality gearheads at precision levels down to less than 1 arc minute (1/60 th of a degree), with consistency and high reliability.

Based on more than twenty years of accumulated manufacturing and marketing experience, plus the highest level of technical production capabilities, Apex Dynamics, Inc. designs and builds technically advanced, high speed, low backlash servo application planetary gearboxes. Our Break through patented technology (over 6 patents), provides the customer with the optimum high precision helical reducer at a reasonable price. We are continuously improving processes, finding proper and effective methods to provide customers new solutions for difficult applications, and developing new products.

The primary focus in daily operation is quality. We pride ourselves on our dedication to quality; our duty - is customer satisfaction.



APEX



AE Series

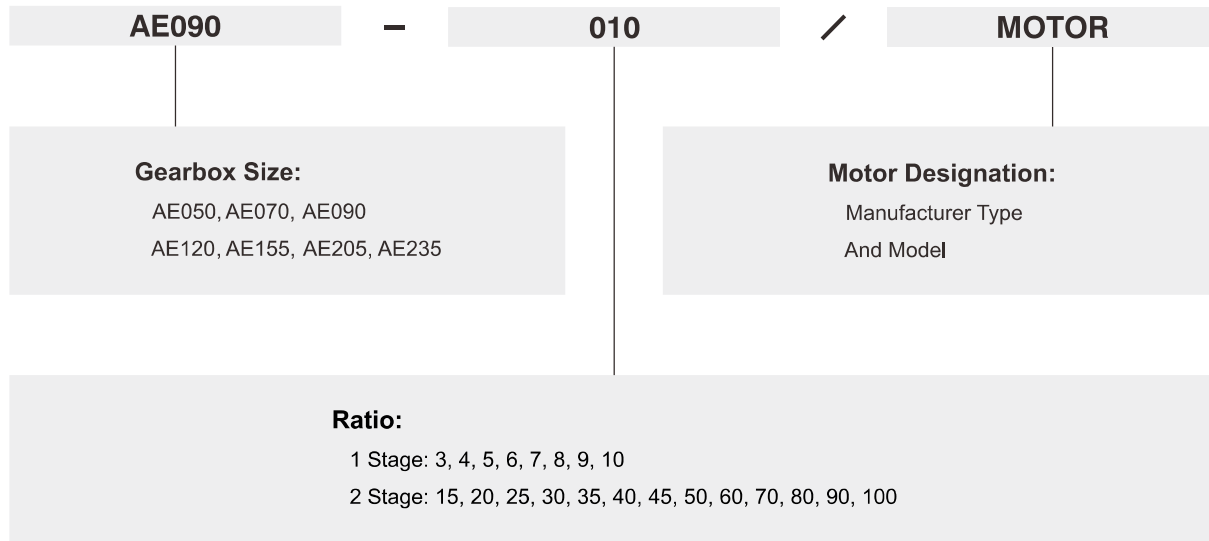

Ordering Example: AE090-010 / SIEMENS 1FT6 041-4AF71

AER Series

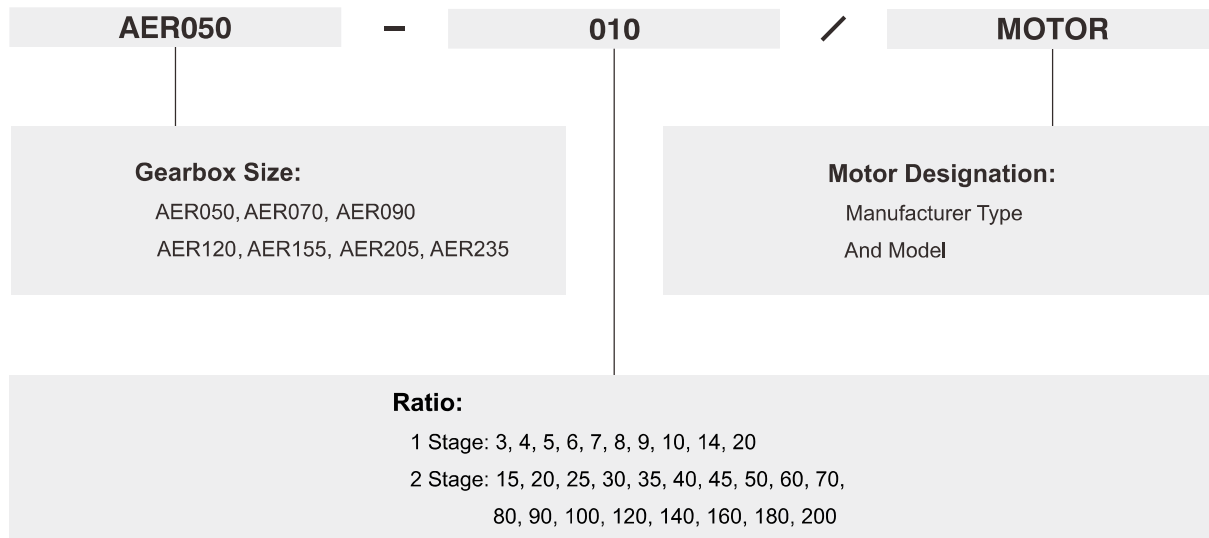

Ordering Example: AER050-010 / SIEMENS 1FT5 034-OAK71

Specifications / AE Series

Gearbox Performance

Model No.	Stage	Ratio ^A	AE050	AE070	AE090	AE120	AE155	AE205	AE235	
Nominal output torque T_{2N}	1	3	20	55	130	208	342	588	1,140	
		4	19	50	140	290	542	1,050	1,700	
		5	22	60	160	330	650	1,200	2,000	
		6	20	55	150	310	600	1,100	1,900	
		7	19	50	140	300	550	1,100	1,800	
		8	17	45	120	260	500	1,000	1,600	
		9	14	40	100	230	450	900	1,500	
		10	14	40	100	230	450	900	1,500	
		2	15	20	55	130	208	342	588	1,140
			20	19	50	140	290	542	1,050	1,700
	25		22	60	160	330	650	1,200	2,000	
	30		20	55	150	310	600	1,100	1,900	
	35		19	50	140	300	550	1,100	1,800	
	40		17	45	120	260	500	1,000	1,600	
	45		14	40	100	230	450	900	1,500	
	50		22	60	160	330	650	1,200	2,000	
	60		20	55	150	310	600	1,100	1,900	
	70		19	50	140	300	550	1,100	1,800	
	80	17	45	120	260	500	1,000	1,600		
	90	14	40	100	230	450	900	1,500		
100	14	40	100	230	450	900	1,500			
Emergency Stop Torque T_{2NOT}^B	Nm	1,2	3~100	3 times of nominal output torque						
Nominal input speed n_{1N}	rpm	1,2	3~100	5,000	5,000	4,000	4,000	3,000	3,000	2,000
Max. input speed n_{1B}	rpm	1,2	3~100	10,000	10,000	8,000	8,000	6,000	6,000	4,000
Backlash	arcmin	1	3~10	≤8	≤8	≤8	≤8	≤8	≤8	≤8
		2	15~100	≤12	≤12	≤12	≤12	≤12	≤12	≤12
Torsional rigidity	Nm/arcmin	1,2	3~100	3	7	14	25	50	145	225
Max. Radial Load F_{2B}^C	N	1,2	3~100	702	1,377	2,985	6,100	8,460	13,050	8,700
Max. Axial Load F_{2aB}^C	N	1,2	3~100	390	765	1,625	3,350	4,700	7,250	5,400
Efficiency η	%	1	3~10	≥97%						
		2	15~100	≥94%						
Weight	kg	1	3~10	0.6	1.4	3.3	6.9	13	31	53
		2	15~100	0.9	1.6	4.7	8.7	17	35	66
Operating temp	°C	1,2	3~100	-10°C~90°C						
Lubrication				Synthetic lubrication oils						
Degree of gearbox protection		1,2	3~100	IP65						
Mounting position		1,2	3~100	all directions						
Noise ^D	dB(A)	1,2	3~100	≤56	≤58	≤60	≤63	≤65	≤67	≤70

Gearbox Inertia

Model No.	Stage	Ratio ^A	AE050	AE070	AE090	AE120	AE155	AE205	AE235	
Mass moments of inertia J_1	1	3	0.03	0.16	0.61	3.25	9.21	28.98	69.61	
		4	0.03	0.14	0.48	2.74	7.54	23.67	54.37	
		5	0.03	0.13	0.47	2.71	7.42	23.29	53.27	
		6	0.03	0.13	0.45	2.65	7.25	22.75	51.72	
		7	0.03	0.13	0.45	2.62	7.14	22.48	50.97	
		8	0.03	0.13	0.44	2.58	7.07	22.59	50.84	
		9	0.03	0.13	0.44	2.57	7.04	22.53	50.63	
		10	0.03	0.13	0.44	2.57	7.03	22.51	50.56	
		2	15	0.03	0.03	0.13	0.47	2.71	7.42	23.29
			20	0.03	0.03	0.13	0.47	2.71	7.42	23.29
	25		0.03	0.03	0.13	0.47	2.71	7.42	23.29	
	30		0.03	0.03	0.13	0.47	2.71	7.42	23.29	
	35		0.03	0.03	0.13	0.47	2.71	7.42	23.29	
	40		0.03	0.03	0.13	0.47	2.71	7.42	23.29	
	45		0.03	0.03	0.13	0.47	2.71	7.42	23.29	
	50		0.03	0.03	0.13	0.44	2.57	7.03	22.51	
	60		0.03	0.03	0.13	0.44	2.57	7.03	22.51	
	70		0.03	0.03	0.13	0.44	2.57	7.03	22.51	
	80	0.03	0.03	0.13	0.44	2.57	7.03	22.51		
	90	0.03	0.03	0.13	0.44	2.57	7.03	22.51		
100	0.03	0.03	0.13	0.44	2.57	7.03	22.51			

A. Ratio ($i=N_{in}/N_{out}$)

B. Max. acceleration torque $T_{2B} = 60\%$ of T_{2NOT}

C. Applied to the output shaft center at 100 rpm

D. The dB values are measured by gearbox with ratio 10 (1-stage) or ratio 100 (2-stage), no loading at 3,000 RPM or at the respective Nominal Input Speed by bigger model size.

By lower ratio and/or higher RPM, the noise level could be 3 to 5 dB higher.

E. 5 years warranty.

Dimensions (1-stage, Ratio $i=3\sim 10$) / AE Series

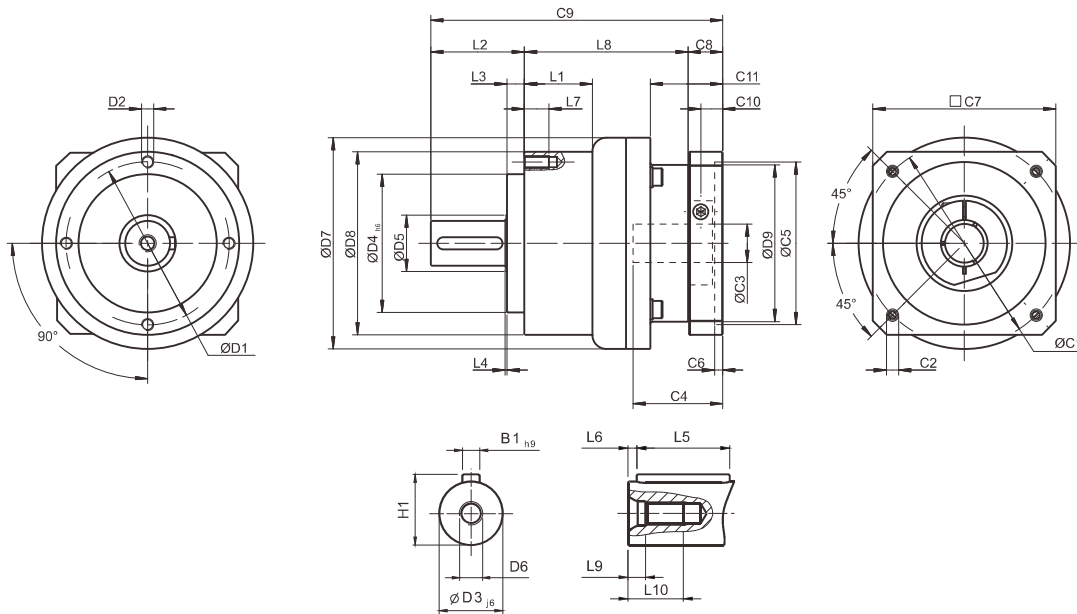

[unit: mm]

Dimension	AE050	AE070	AE090	AE120	AE155	AE205	AE235
D1	44	62	80	108	140	184	210
D2	M4 x 0.7P	M5 x 0.8P	M6 x 1P	M8 x 1.25P	M10 x 1.5P	M12 x 1.75P	M16 x 2P
D3 _{j6}	12	16	22	32	40	55	75
D4 _{h6}	35	52	68	90	120	160	180
D5	22	22	30	40	75	95	115
D6	M4 x 0.7P	M5 x 0.8P	M8 x 1.25P	M12 x 1.75P	M16 x 2P	M20 x 2.5P	M20 x 2.5P
D7	53	70	104	130	162	205	260
D8	50	70	90	120	155	205	235
D9	45.5	53.4	77	102	125	160	205
L1	--	--	33.5	38	50	--	70
L2	24.5	36	46	70	97	100	126
L3	4	6.5	8.5	17.5	15	15	18
L4	1	1	1	1.5	3	3	3
L5	14	25	32	40	63	70	90
L6	2	2	3	5	5	6	7
L7	8	10	12	16	20	22	28
L8	47	62	80.5	97	119.5	159	175.5
L9	4.5	4.8	7.2	10	12	15	15
L10	10	12.5	19	28	36	42	42
C1 ¹	46	70	100	130	165	215	235
C2 ³	M4 x 0.7P	M5 x 0.8P	M6 x 1P	M8 x 1.25P	M10 x 1.5P	M12 x 1.75P	M12 x 1.75P
C3 ¹	≤11 / ≤12 ²	≤14 / ≤16 ²	≤19 / ≤24 ²	≤32	≤38	≤48	≤55
C4 ¹	30	34	40	50	60	85	116
C5 ¹	30	50	80	110	130	180	200
C6 ¹	3.5	8	4	5	6	6	6
C7 ¹	48	60	90	115	142	190	220
C8 ¹	19.5	19	17	19.5	22.5	29	63
C9 ¹	91	117	143.5	186.5	239	288	364.5
C10 ¹	13.25	13.5	10.75	13	15	20.75	53.5
C11 ¹	19.5	37	35.5	46	53.5	79.5	106.5
B1 _{h9}	4	5	6	10	12	16	20
H1	14	18	24.5	35	43	59	79.5

1. C1~C11 are motor specific dimensions (metric std shown). Refer to www.apexdyna.com and Design Tool to view your specific motor mounting system.
 2. AE050M1 ratio 5, 10 offers C3 ≤ 12 option; AE070M1 ratio 5, 10 offers C3 ≤ 16 option; AE090M1 offers C3 ≤ 24 option.

Dimensions (2-stage, Ratio $i=15\sim 100$) / AE Series

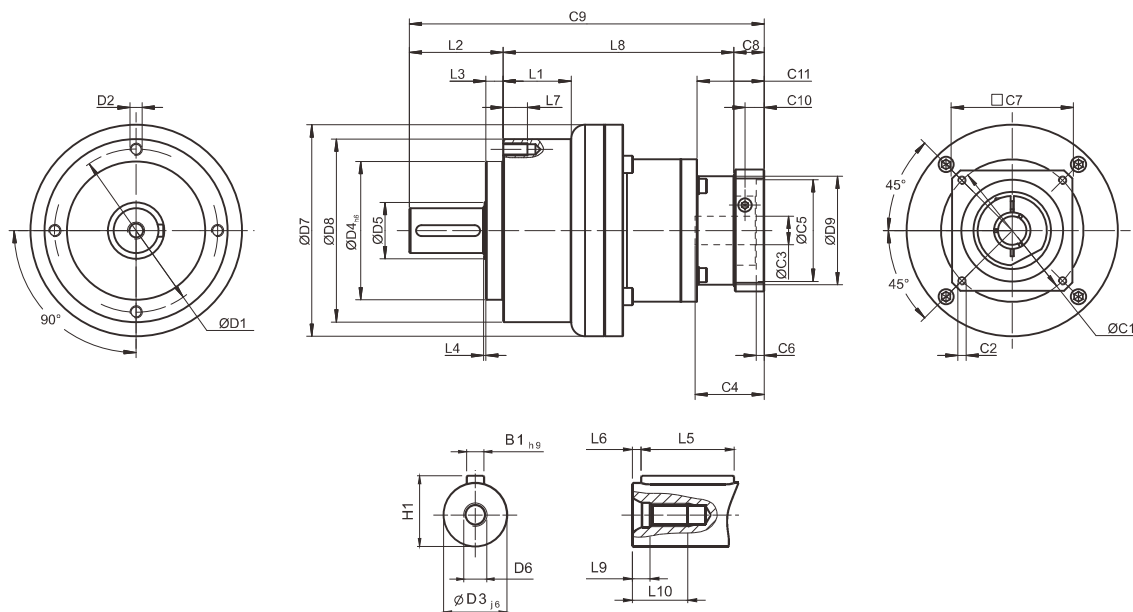

[unit: mm]

Dimension	AE050	AE070	AE090	AE120	AE155	AE205	AE235
D1	44	62	80	108	140	184	210
D2	M4 x 0.7P	M5 x 0.8P	M6 x 1P	M8 x 1.25P	M10 x 1.5P	M12 x 1.75P	M16 x 2P
D3 _{j6}	12	16	22	32	40	55	75
D4 _{h6}	35	52	68	90	120	160	180
D5	22	22	30	40	75	95	115
D6	M4 x 0.7P	M5 x 0.8P	M8 x 1.25P	M12 x 1.75P	M16 x 2P	M20 x 2.5P	M20 x 2.5P
D7	53	70	104	130	162	205	260
D8	50	70	90	120	155	205	235
D9	45.5	45.5	53.4	77	102	125	160
L1	--	--	33.5	38	50	--	70
L2	24.5	36	46	70	97	100	126
L3	4	6.5	8.5	17.5	15	15	18
L4	1	1	1	1.5	3	3	3
L5	14	25	32	40	63	70	90
L6	2	2	3	5	5	6	7
L7	8	10	12	16	20	22	28
L8	74	87.5	113.5	138.5	176	214.5	260
L9	4.5	4.8	7.2	10	12	15	15
L10	10	12.5	19	28	36	42	42
C1 ³	46	46	70	100	130	165	215
C2 ³	M4 x 0.7P	M4 x 0.7P	M5 x 0.8P	M6 x 1P	M8 x 1.25P	M10 x 1.5P	M12 x 1.75P
C3 ³	$\leq 11 / \leq 12^4$	$\leq 11 / \leq 12^4$	$\leq 14 / \leq 15.875 / \leq 16^4$	$\leq 19 / \leq 24^4$	≤ 32	≤ 38	≤ 48
C4 ³	30	30	34	40	50	60	85
C5 ³	30	30	50	80	110	130	180
C6 ³	3.5	3.5	8	4	5	6	6
C7 ³	48	48	60	90	115	142	190
C8 ³	19.5	19.5	19	17	19.5	22.5	29
C9 ³	118	143	178.5	225.5	292.5	337	415
C10 ³	13.25	13.25	13.5	10.75	13	15	20.75
C11 ³	19.5	19.5	37	35.5	46	53.5	79.5
B1 _{h9}	4	5	6	10	12	16	20
H1	14	18	24.5	35	43	59	79.5

3. C1~C11 are motor specific dimensions (metric std shown). Refer to www.apexdyna.com and Design Tool to view your specific motor mounting system.
 4. AE050M1 C3 ≤ 12 option; AE070M1 offers C3 ≤ 12 option; AE090M1/M2 offers C3 $\leq 16/15.875$ option; AE120M1 offers C3 ≤ 24 .

Specifications / AER Series

Gearbox Performance

Model No.		Stage	Ratio ^A	AER050	AER070	AER090	AER120	AER155	AER205	AER235
Nominal output torque T_{2N}	Nm	1	3	9	36	90	195	342	588	1,140
			4	12	48	120	260	520	1,040	1,680
			5	15	60	150	325	650	1,200	2,000
			6	18	55	150	310	600	1,100	1,900
			7	19	50	140	300	550	1,100	1,800
			8	17	45	120	260	500	1,000	1,600
			9	14	40	100	230	450	900	1,500
			10	14	60	150	325	650	1,200	2,000
			14	-	42	140	300	550	1,100	1,800
		20	-	40	100	230	450	900	1,500	
		15	14	-	-	-	-	-	-	-
		20	14	-	-	-	-	-	-	-
		25	15	60	150	325	650	1,200	2,000	
		30	20	55	150	310	600	1,100	1,900	
		35	19	50	140	300	550	1,100	1,800	
		40	17	45	120	260	500	1,000	1,600	
		45	14	40	100	230	450	900	1,500	
		50	14	60	150	325	650	1,200	2,000	
		60	20	55	150	310	600	1,100	1,900	
		70	19	50	140	300	550	1,100	1,800	
		80	17	45	120	260	500	1,000	1,600	
		90	14	40	100	230	450	900	1,500	
		100	14	40	100	230	450	900	1,500	
		120	-	-	150	310	600	1,100	1,900	
140	-	-	140	300	550	1,100	1,800			
160	-	-	120	260	550	1,000	1,600			
180	-	-	100	230	450	900	1,500			
200	-	-	100	230	450	900	1,500			
Emergency Stop Torque T_{2NOT}^B	Nm	1,2	3~200	3 times of nominal output torque						
Nominal Input Speed n_{1N}	rpm	1,2	3~200	5,000	5,000	4,000	4,000	3,000	3,000	2,000
Max. Input Speed n_{1B}	rpm	1,2	3~200	10,000	10,000	8,000	8,000	6,000	6,000	4,000
Backlash	arcmin	1	3~20	≤10	≤10	≤10	≤10	≤10	≤10	≤10
		2	25~200	≤14	≤14	≤14	≤14	≤14	≤14	≤14
Torsional Rigidity	Nm/arcmin	1,2	3~200	3	7	14	25	50	145	225
Max. Radial Load F_{2rB}^C	N	1,2	3~200	702	1,377	2,985	6,100	8,460	13,050	8,700
Max. Axial Load F_{2aB}^C	N	1,2	3~200	390	765	1,625	3,350	4,700	7,250	5,400
Efficiency η	%	1	3~20	≥95%						
		2	25~200	≥92%						
Weight	kg	1	3~20	1.0	2.1	5.8	11.2	22.4	46.8	78.0
		2	25~200	1.3	2.0	4.6	11.1	21.8	43.7	81.9
Operating temp	°C	1,2	3~200	-10°C~90°C						
Lubrication				Synthetic lubrication oils						
Degree of gearbox protection		1,2	3~200	IP65						
Mounting position		1,2	3~200	all directions						
Noise ^D	dB(A)	1,2	3~200	≤61	≤63	≤65	≤68	≤70	≤72	≤74

Gearbox Inertia

Model No.		Stage	Ratio ^A	AER050	AER070	AER090	AER120	AER155	AER205	AER235
Mass Moments of Inertia J_i	kg · cm ²	1	3~10	0.09	0.35	2.25	6.84	23.4	68.9	135.4
			14	-	0.07	1.87	6.25	21.8	65.6	119.8
			20	-	0.07	1.87	6.25	21.8	65.6	119.8
		2	15	0.09	-	-	-	-	-	-
			20	0.09	-	-	-	-	-	-
			25~100	0.09	0.09	0.35	2.25	6.84	23.4	68.9
			120~200	-	-	0.31	1.87	6.25	21.8	65.6

A. Ratio ($i=N_{in}/N_{out}$)

B. Max. acceleration torque $T_{2B} = 60\%$ of T_{2NOT}

C. Applied to the output shaft center at 100 rpm

D. The dB values are measured by gearbox with ratio 10 (1-stage) or ratio 100 (2-stage), no loading at 3,000 RPM or at the respective Nominal Input Speed by bigger model size.

By lower ratio and/or higher RPM, the noise level could be 3 to 5 dB higher.

E. 5 years warranty.

Dimensions (1-stage, Ratio $i=3\sim 20$) / AER Series

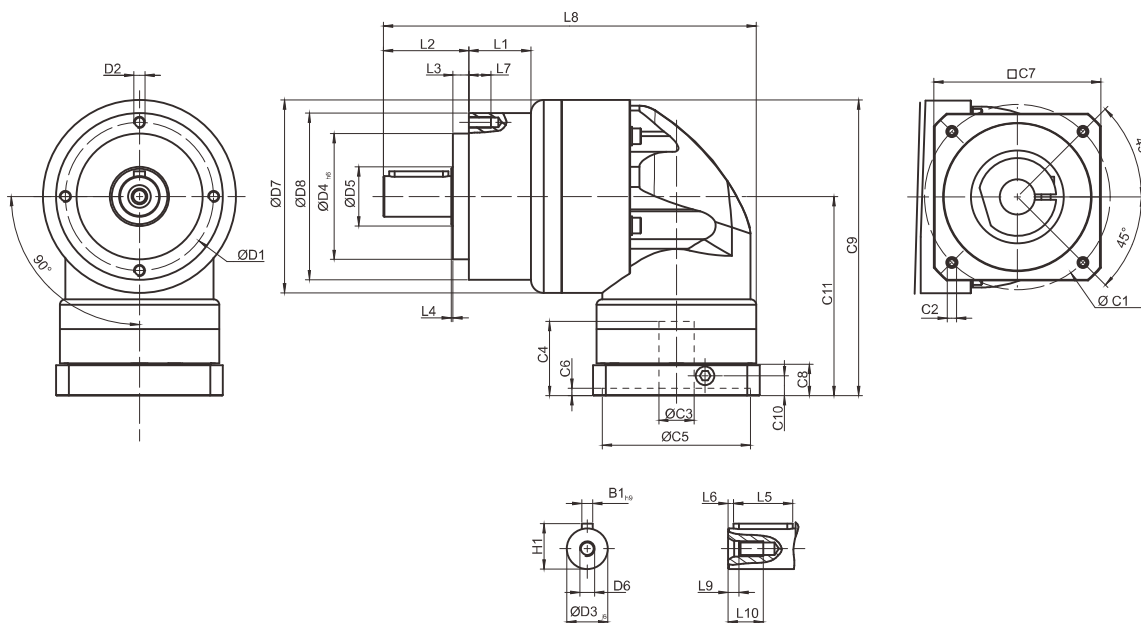

[unit: mm]

Dimension	AER050	AER070	AER090	AER120	AER155	AER205	AER235
D1	44	62	80	108	140	184	210
D2	M4 x 0.7P	M5 x 0.8P	M6 x 1P	M8 x 1.25P	M10 x 1.5P	M12 x 1.75P	M16 x 2P
D3 _{j6}	12	16	22	32	40	55	75
D4 _{h6}	35	52	68	90	120	160	180
D5	22	22	30	40	75	95	115
D6	M4 x 0.7P	M5 x 0.8P	M8 x 1.25P	M12 x 1.75P	M16 x 2P	M20 x 2.5P	M20 x 2.5P
D7	53	70	104	130	162	205	260
D8	50	70	90	120	155	205	235
L1	--	--	33.5	38	50	--	70
L2	24.5	36	46	70	97	100	126
L3	4	6.5	8.5	17.5	15	15	18
L4	1	1	1	1.5	3	3	3
L5	14	25	32	40	63	70	90
L6	2	2	3	5	5	6	7
L7	8	10	12	16	20	22	28
L8	115.5	146	201	252	324.5	379.5	461.5
L9	4.5	4.8	7.2	10	12	15	15
L10	10	12.5	19	28	36	42	42
C1 ¹	46	70	100	130	165	215	235
C2 ¹	M4 x 0.7P	M5 x 0.8P	M6 x 1P	M8 x 1.25P	M10 x 1.5P	M12 x 1.75P	M12 x 1.75P
C3 ¹	≤11 / ≤12 ²	≤14 / ≤16 ²	≤19 / ≤24 ²	≤32	≤38	≤48	≤55
C4 ¹	30	34	40	50	60	85	116
C5 ¹	30	50	80	110	130	180	200
C6 ¹	3.5	8	4	5	6	6	6
C7 ¹	48	60	90	115	142	190	220
C8 ¹	19.5	19	17	19.5	22.5	29	63
C9 ¹	100.5	116.5	159.5	199	245.5	316	398.5
C10 ¹	13.25	13.5	10.75	13	15	20.75	53.5
C11 ¹	74	81.5	107.5	134	164.5	213.5	268.5
B1 _{h9}	4	5	6	10	12	16	20
H1	14	18	24.5	35	43	59	79.5

1. C1~C11 are motor specific dimensions (metric std shown). Refer to www.apexdyna.com and Design Tool to view your specific motor mounting system.
 2. AER050M1 offers C3 ≤ 12 option; AER070M1 offers C3 ≤ 16 option; AER090M1 offers C3 ≤ 24 option.

Dimensions (2-stage, Ratio $i=15\sim 200$) / AER Series

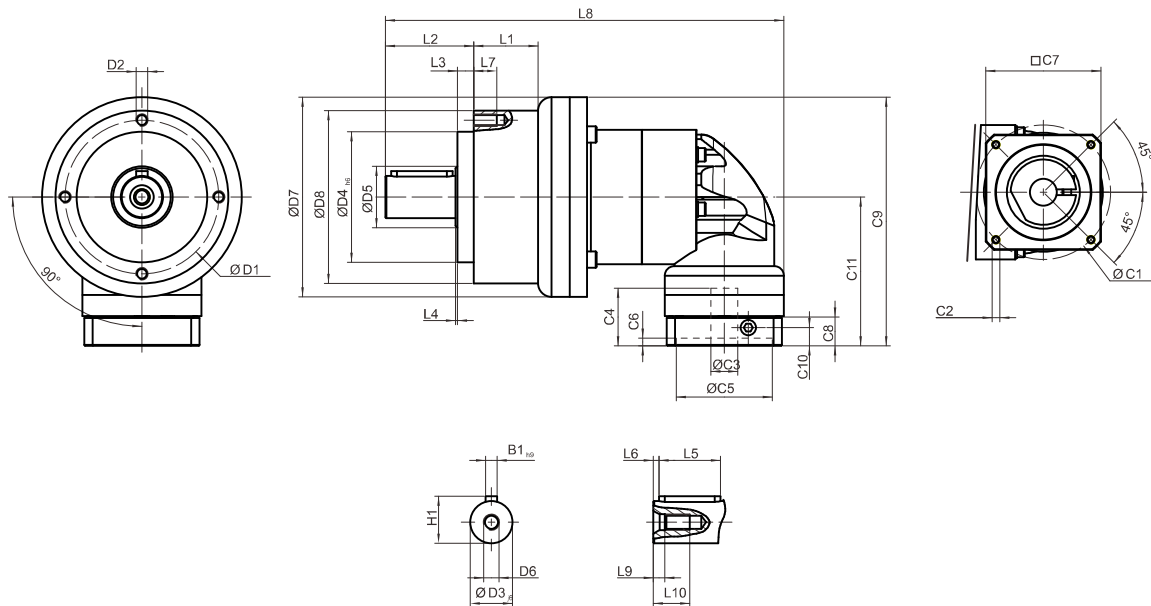

[unit: mm]

Dimension	AER050	AER070	AER090	AER120	AER155	AER205	AER235
D1	44	62	80	108	140	184	210
D2	M4 x 0.7P	M5 x 0.8P	M6 x 1P	M8 x 1.25P	M10 x 1.5P	M12 x 1.75P	M16 x 2P
D3 _{j6}	12	16	22	32	40	55	75
D4 _{h6}	35	52	68	90	120	160	180
D5	22	22	30	40	75	95	115
D6	M4 x 0.7P	M5 x 0.8P	M8 x 1.25P	M12 x 1.75P	M16 x 2P	M20 x 2.5P	M20 x 2.5P
D7	53	70	104	130	162	205	260
D8	50	70	90	120	155	205	235
L1	--	--	33.5	38	50	--	70
L2	24.5	36	46	70	97	100	126
L3	4	6.5	8.5	17.5	15	15	18
L4	1	1	1	1.5	3	3	3
L5	14	25	32	40	63	70	90
L6	2	2	3	5	5	6	7
L7	8	10	12	16	20	22	28
L8	142.5	167.5	207.5	283	358	422.5	506.5
L9	4.5	4.8	7.2	10	12	15	15
L10	10	12.5	19	28	36	42	42
C1 ²	46	46	70	100	130	165	215
C2 ²	M4 x 0.7P	M4 x 0.7P	M5 x 0.8P	M6 x 1P	M8 x 1.25P	M10 x 1.5P	M12 x 1.75P
C3 ²	$\leq 11 / \leq 12^3$	$\leq 11 / \leq 12^3$	$\leq 14 / \leq 15.875 / \leq 16^3$	$\leq 19 / \leq 24^3$	≤ 32	≤ 38	≤ 48
C4 ²	30	30	34	40	50	60	85
C5 ²	30	30	50	80	110	130	180
C6 ²	3.5	3.5	8	4	5	6	6
C7 ²	48	48	60	90	115	142	190
C8 ²	19.5	19.5	19	17	19.5	22.5	29
C9 ²	100.5	109	133.5	172.5	215	267	343.5
C10 ²	13.25	13.25	13.5	10.75	13	15	20.75
C11 ²	74	74	81.5	107.5	134	164.5	213.5
B1 _{h9}	4	5	6	10	12	16	20
H1	14	18	24.5	35	43	59	79.5

2. C1~C11 are motor specific dimensions (metric std shown). Refer to www.apexdyna.com and Design Tool to view your specific motor mounting system.
 3. AER050M1 offers C3 ≤ 12 option; AER070M1 offers C3 ≤ 12 option; AER090M1/M2 offers C3 $\leq 16/15.875$ option; AER120M1 offer C3 ≤ 24 .

Permitted Radial and Axial Loads

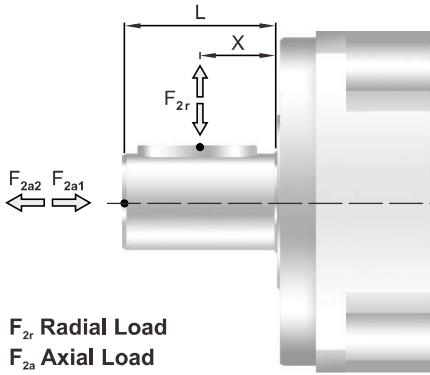

The permitted radial and axial loads on output shaft of the gearbox depend on the design of the gearbox supporting bearings. APEX use the extension straddle oversized ball bearing design. It can take heavy load from both axes.

F_{2r} Radial Load
 F_{2a} Axial Load

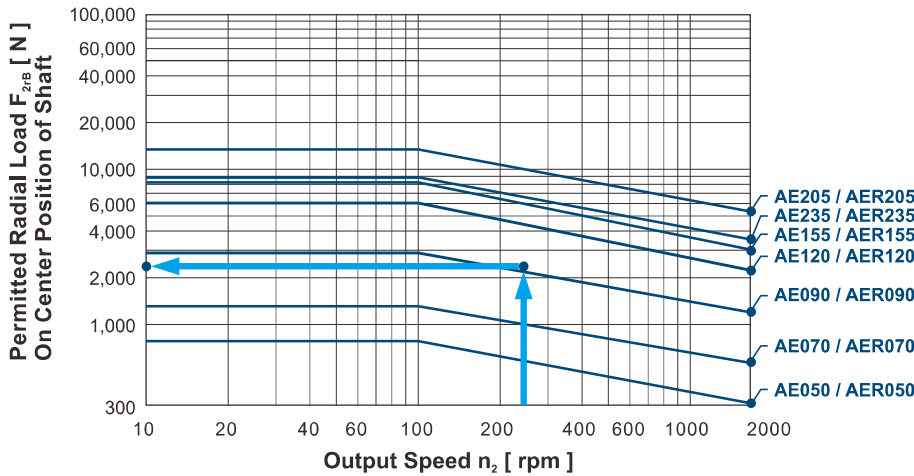

If radial force F_{2r} exert on the center of the output shaft $X=1/2 \times L$. The permitted radial load is given on left diagram.

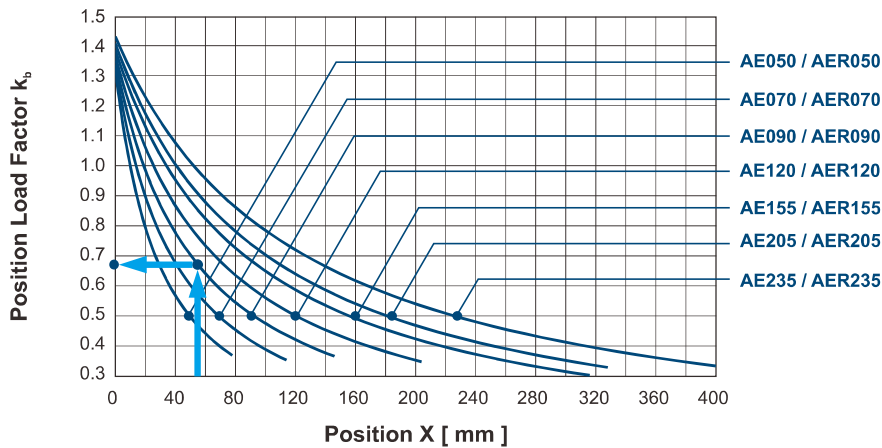

If radial force F_{2r} not exert on the center of the output shaft $X < 1/2 \times L$ or $X > 1/2 \times L$. The permitted radial and axial load can be calculated by the position load factor k_0 on the left diagram.

Front Plate Option

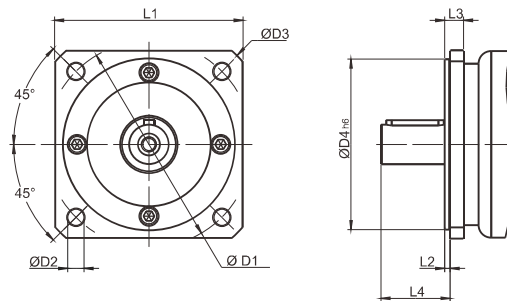

[unit: mm]

Dimension	D1	D2	D3	D4 ^{h6}	L1	L2	L3	L4
AE050(AER050)-NEMA 23	66.675	6	77	38.1	57.2	2	8	18.5
AE050(AER050)-PX60	70	5.6	80.5	50	60	2.5	8.5	18.5
AE070(AER070)-Metric	90	6.6	106	50	80	3	11	28
AE070(AER070)-NEMA 34	98.425	5.5	115	73.025	86	2.5	8	30.5
AE070(AER070)-DT90 / PX90	100	6.6	120	80	90	3	8	31
AE090(AER090)-IEC 63D5 B5	115	9	140	95	105	3	10.5	38.5
AE090(AER090)-NEMA 34	98.425	5.5	120	73.025	92	2.5	12.5	36
AE090(AER090)-DT90 / PX90	100	6.5	120	80	92	2.5	12.5	36
AE090(AER090)-NEMA 42	125.73	7	144	55.58	107	4	14.5	35.5
AE120(AER120)-NEMA 42	125.73	7.1	170	55.499	127	1.5	21.5	50
AE120(AER120)-NEMA 56	149.225	6.6	170	114.3	127	3	17.5	55.5
AE155(AER155)-B5	175	11	196	130	160	5	20	82
AE205(AER205)-B5	230	13	277	180	210	5	23	82
AE235(AER235)-B5	275	17	317	235	240	5	23	108

Selection of the optimum gearbox

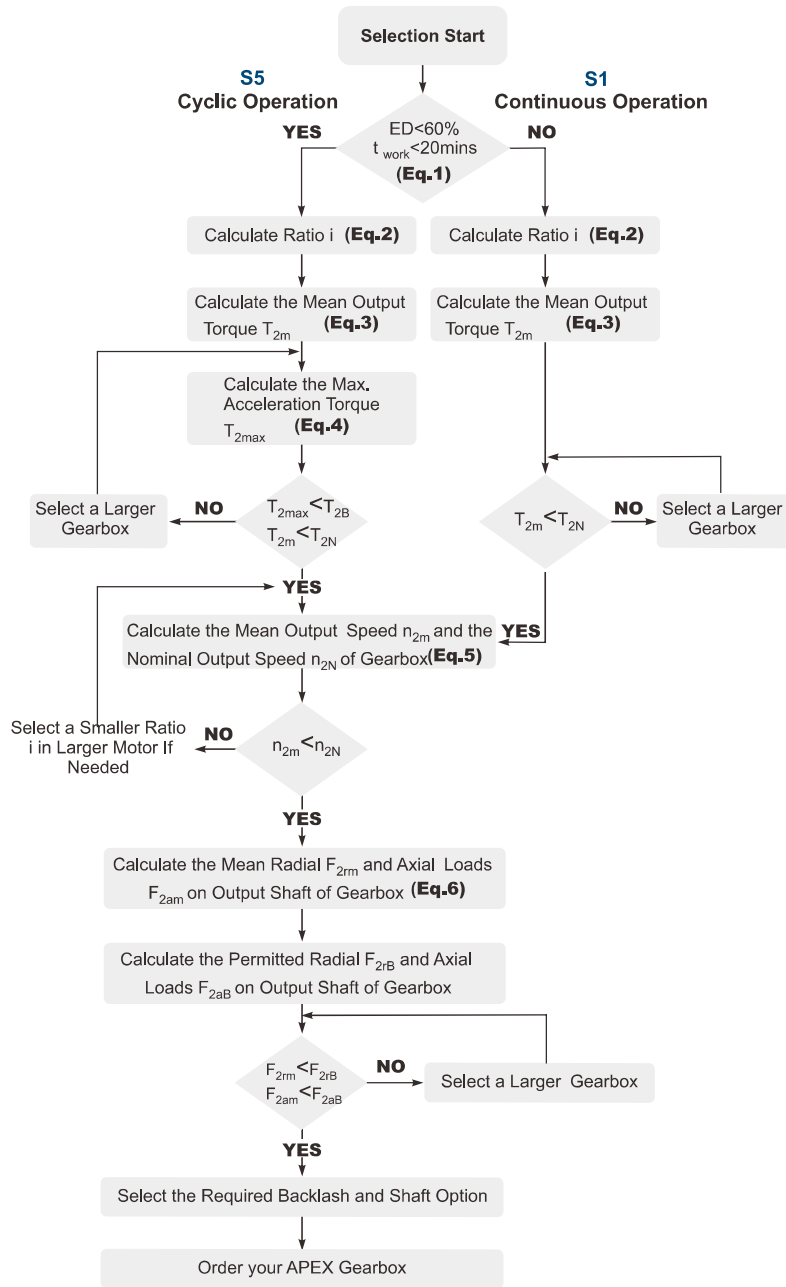

Recommended (for S5 Cycle Operation)

The general design is given for

$$\frac{J_L}{i^2} \leq 4 \times J_m$$

The optimal design is given for

$$\frac{J_L}{i^2} \approx J_m$$

J_L Load Inertia

J_m Motor Inertia

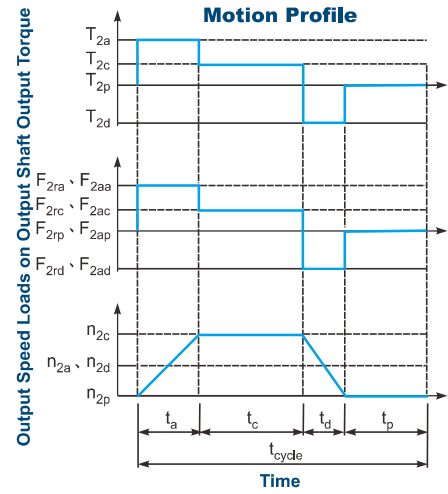

$$1. ED = \frac{t_a + t_c + t_d}{t_{cycle}} \times 100\%, t_{work} = t_a + t_c + t_d$$

Index : a. Acceleration, c. Constant,
d. Deceleration, p. Pause

(Eq.1)

$$2. i \approx \frac{n_m}{n_{work}}$$

n_m Output Speed of the Motor

n_{work} Working Speed

(Eq.2)

$$3. T_{2m} = \sqrt[3]{\frac{n_{2a} \times t_a \times T_{2a}^3 + n_{2c} \times t_c \times T_{2c}^3 + n_{2d} \times t_d \times T_{2d}^3}{n_{2a} \times t_a + n_{2c} \times t_c + n_{2d} \times t_d}}$$

(Eq.3)

$$4. T_{2max} = T_{mB} \times i \times K_s \times \eta$$

where K_s is

K_s	No. of Cycles / hr
1.0	0 ~ 1,000
1.1	1,000 ~ 1,500
1.3	1,500 ~ 2,000
1.6	2,000 ~ 3,000
1.8	3,000 ~ 5,000

T_{mB} Max. Output Torque of the Motor

η Efficiency of the Gearbox

(Eq.4)

$$5. n_{2a} = n_{2d} = \frac{1}{2} \times n_{2c}$$

$$n_{2m} = \frac{n_{2a} \times t_a + n_{2c} \times t_c + n_{2d} \times t_d}{t_a + t_c + t_d}$$

$$n_{2N} = \frac{n_{1N}}{i}$$

(Eq.5)

$$6. F_{2rm} = \sqrt[3]{\frac{n_{2a} \times t_a \times F_{2ra}^3 + n_{2c} \times t_c \times F_{2rc}^3 + n_{2d} \times t_d \times F_{2rd}^3}{n_{2a} \times t_a + n_{2c} \times t_c + n_{2d} \times t_d}}$$

$$F_{2am} = \sqrt[3]{\frac{n_{2a} \times t_a \times F_{2aa}^3 + n_{2c} \times t_c \times F_{2ac}^3 + n_{2d} \times t_d \times F_{2ad}^3}{n_{2a} \times t_a + n_{2c} \times t_c + n_{2d} \times t_d}}$$

(Eq.6)

Glossary

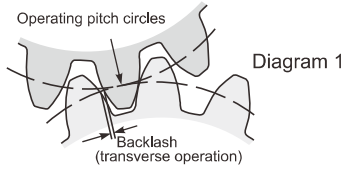
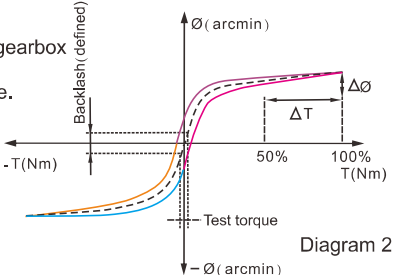
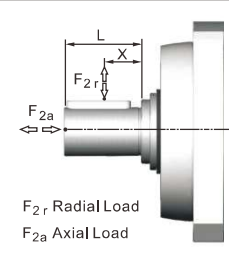
Emergency Stop Torque T_{2NOT}	Nm	The Emergency Stop Torque is the maximum permitted torque at the output of gearbox. This may happen only occasionally and may not exceed 1,000 times during the whole service life.
Max. Acceleration Torque T_{2B}	Nm	Under the Cyclic Operation (S5), the Max. Acceleration Torque is the maximum torque which can be transmitted only briefly to the output of gearbox up to 1,000 cycles/hr.
No Load Running Torque	Nm	The No Load Running Torque is the min. torque to overcome the internal friction of a gearbox without loading*.
Nominal Input Speed n_{1N}	rpm	The Nominal Input Speed is the permitted input speed of gearbox by the Continuous Operation (S1) while the housing temperature does not exceed 90°C. This value is measured at environment temperature 25°C.
Max. Input Speed n_{1B}	rpm	The Max. Input Speed is the max. permitted input speed of gearbox by the Cyclic operation (S5). This value is measured at environment temperature 25°C and serves as the absolute limit of the gearbox.
Backlash	arcmin	<p>The Backlash is the maximum angular measurement between two teeth of gears when the transverse operation occurs (refer to Diagram 1). The arcmin is the measurement unit for the backlash. One arcmin equals 1/60 degree, symbolized as 1'.</p>  <p style="text-align: right;">Diagram 1</p>
Torsional Rigidity	Nm/arcmin	<p>Torsional Rigidity is the quotient ($\Delta T / \Delta \theta$) between the applied torque and resulting torsion angle. This value indicates how much torque is needed on the gearbox to rotate the output shaft for 1 arcmin. The Torsional Rigidity can be determined by Hysteresis Curve.</p> <p>Hysteresis Curve When the input shaft is locked, increase torque at the output slowly up to T_{2B} in both directions and then release the torque gradually. According to the measured torque and torsion angle, a closed curve will be acquired as in the Diagram 2.</p>  <p style="text-align: right;">Diagram 2</p>
Radial Load And Axial Load	N	<p>The permitted radial and axial loads on output shaft of the gearbox depend on the design of the gearbox supporting bearings.</p> <p>For more information, please refer to APEX website.</p>  <p style="text-align: center;">F_{2r} Radial Load F_{2a} Axial Load</p>
Efficiency η	%	The transmission efficiency of the gears inside a gearbox (without friction).
Operating Temperature	°C	The Operating Temperature indicates the temperature of gearbox housing.
Degree of Protection		IP code stands for International Protection standard. The IP65 as example: the first IP number stands for protection degree against dust; the second IP number stands for protection against liquid.
Lubrication		APEX uses synthetic lubrication grease. Alternate greases are available, please contact APEX.
Running Noise	dB(A)	The Running Noise is measured depends on gearbox size, the ratio and the speed*. Higher speed usually induces higher noise level, while higher ratio induces lower noise level.
Moment of Inertia J_1	kg.cm ²	The Moment of Inertia J_1 is a measurement of the effort applied to an object to maintain its momentary condition at rest or rotating.
Breakaway Torque	Nm	The Breakaway Torque is the minimum torque to start the rotation from the input side of gearbox. A smaller size or a higher ratio gearbox requests less Breakaway Torque.
Back Driving Torque	Nm	The Back Driving Torque is the minimum torque to start the rotation from the output side of gearbox. A larger size or a higher ratio gearbox requires greater Back Driving Torque.

* This value is measured at environment temperature 25°C and the input speed 3,000 rpm. If the Nominal Input Speed n_{1N} of gearbox is lower than 3,000 rpm, this value is measured by that specific Nominal Input Speed.